

## TEACHER'S GUIDE™

ELEMENTARY MATH  
AND GEOMETRY™

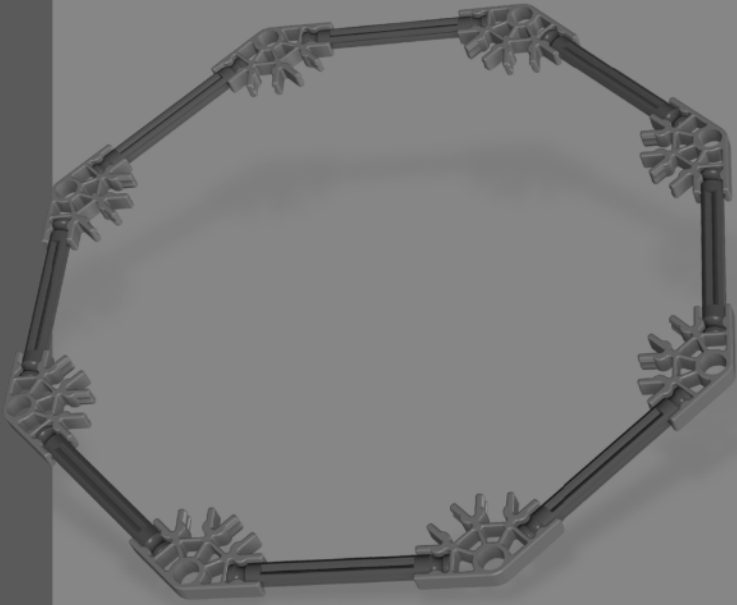

**OCTAGON**



**3-D SHAPES**

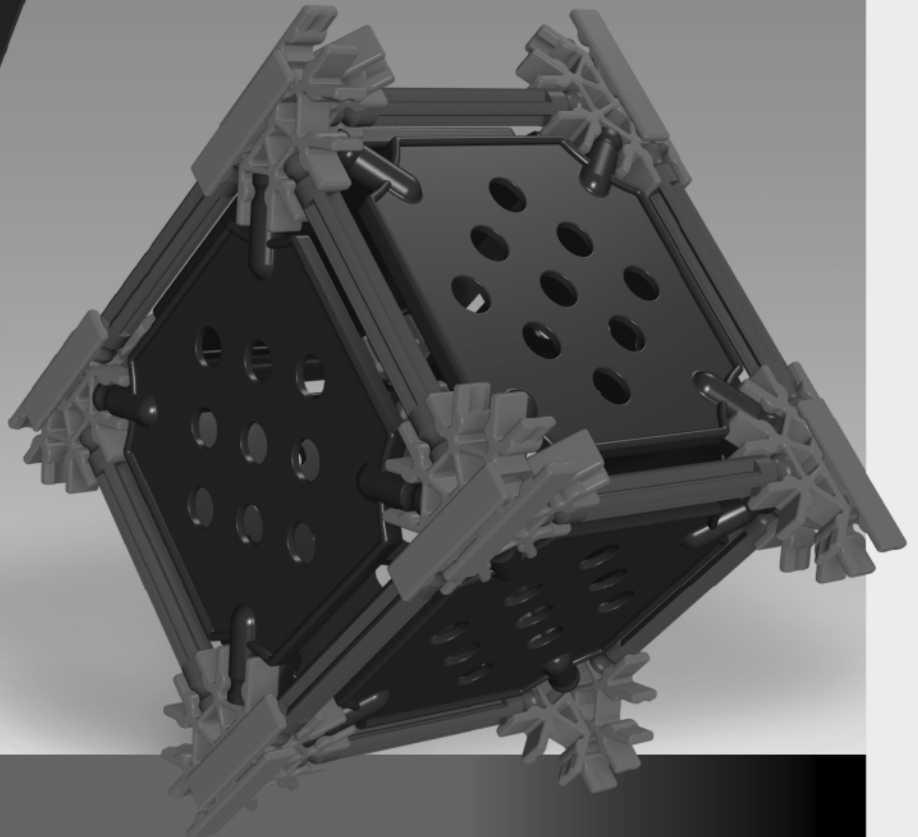
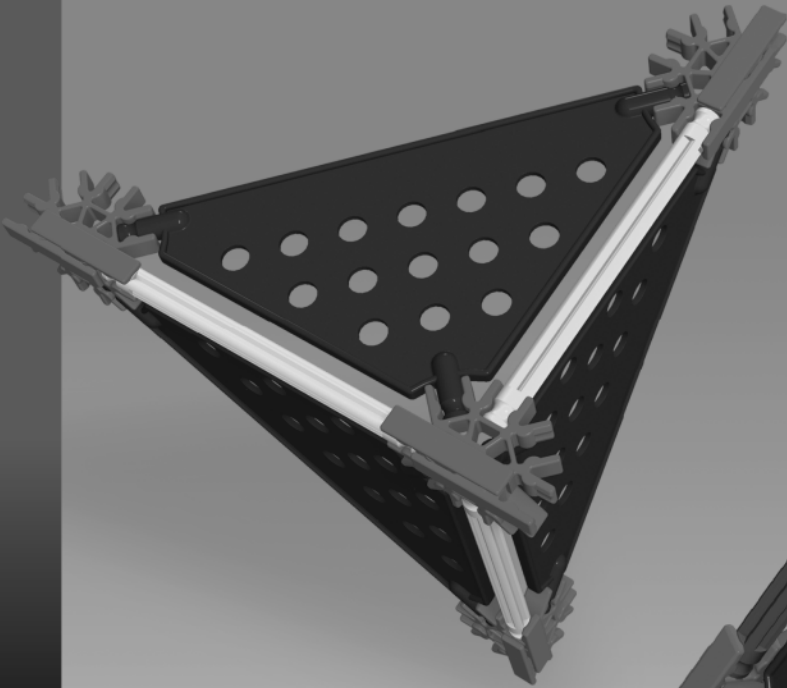



# ELEMENTARY MATH AND GEOMETRY

## Teacher's Guide

KNX 96220-V2  
© 2007 K'NEX Limited Partnership Group  
and its licensors.

K'NEX Limited Partnership Group  
P.O. Box 700  
Hatfield, PA 19440-0700

Visit our website at [www.knexeducation.com](http://www.knexeducation.com)  
Email: [abcknex@knex.com](mailto:abcknex@knex.com)  
Phone: 1-888-ABC-KNEX (Toll Free)

Conforms to the Requirements of ASTM  
Standard Consumer Safety Specification on  
Toy Safety, F963-03.  
Manufactured under U.S. Patents 5,061,219;  
5,199,919; 5,350,331; 5,137,486.  
Other U.S. and foreign patents pending.  
Protected by International Copyright.  
All rights reserved.  
Printed in the United States of America.

Text:  
Patricia Pierantozzi  
Centennial School District  
Warminster, Pennsylvania, 18974  
Teleflex Fellowship Scholar 1995;  
Disney American Teacher Award  
Nominee 1999, 2001, 2003;  
Presidential Award for Excellence in  
Mathematics and Science Teaching 2000.

Acknowledgements:  
The mathematical definitions are reprinted  
with permission from IMAGES: Improving  
Measurement and Geometry in Elementary  
Schools. This entire publication can be  
purchased from Research for Better Schools  
at <http://www.rbs.org>.

 **WARNING:**  
**CHOKE HAZARD - Small parts.**  
**Not for children under 3 years.**





## TABLE OF CONTENTS

<b>Math Guide</b>	<b>6-72</b>
<b>Overview</b>	<b>3</b>
<b>NTCM Standards (Grades 3-5)</b>	<b>4-5</b>
<b>Lessons and Terms</b>	
Lesson 1: Introductory Activity	6-8
Lesson 2: Lines and Angles Line and Angle Terms	9-12 11-12
Lesson 3: Triangles Triangle Terms	13-15 15
Lesson 4: Squares and Rectangles Square and Rectangle Terms	16-19 19
Lesson 5: Quadrilaterals Quadrilateral Terms	20-22 22
Lesson 6: More 2-D Shapes More 2-D Shape Terms	23-25 25
Lesson 7: Cubes and Rectangular Prisms Cube and Rectangular Prism Terms	26-29 29
Lesson 8: Pyramids Pyramid Terms	30-32 32
Lesson 9: More 3-D Shapes More 3-D Shape Terms	33-35 35
Lesson 10: 2-D and 3-D Symmetry 2-D and 3-D Symmetry Terms	36-38 38
Lesson 11: More Symmetry More Symmetry Terms	39-40 40
Lesson 12: Patterns and Fractions Pattern and Fraction Terms	41-43 43
<b>Vocabulary Flash Cards</b>	<b>45-72</b>

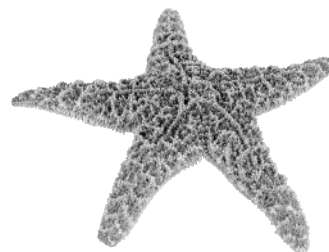
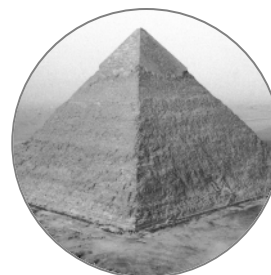
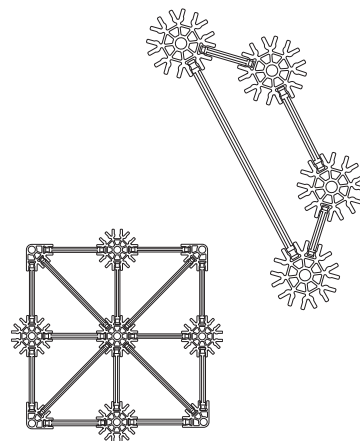

# Overview

square

rectangle

*This teacher's guide has been developed to support you as your students investigate mathematics concepts with the K'NEX Education Elementary Math and Geometry Set. The Rods and Connectors provided in this K'NEX Education Set will enable your students to construct models of polygons, polyhedra, patterns, and examples of symmetrical structures that will bring mathematics and geometry to life before their eyes. Use this guide to channel their inquiries into active and meaningful learning experiences.*

## **K'NEX Education's Elementary Math and Geometry Set**

This set allows students to work cooperatively, interacting with each other as they build, investigate, discuss, and explore geometry concepts, vocabulary, and structures in a 2-D and 3-D world. The activities are standards-based and designed around best practices in mathematics instruction. The students live in a 3-D world, so it makes sense for them to connect with geometry on a 3-D level. Even some of the 2-D concepts are best understood when they are held and manipulated. K'NEX allows them do just that. Your students' world is hands-on and their instruction should be too.

The building instructions booklet included with the set will assist students as they build the models that will guide their instruction. Each section of the building instructions booklet includes a few questions to pique student curiosity and to focus their investigations. These questions are especially useful if you plan to use a single K'NEX Education Elementary Math and Geometry Set as a geometry center in your classroom.

## **Teacher's Guide**

Designed as a resource for the teacher, this guide provides a glossary of key terms and definitions, includes Vocabulary Card masters to support instruction and understanding, as well as listings of the NCTM standards to which the activities are aligned. Student objectives for each activity are also identified. This guide offers plans and scripts that will facilitate your successful presentation of the math and geometry concepts addressed in the various activities. Most of the activities can be presented in a 30-45 minute class session, although some of the later activities may require one hour for students to complete the activity and adequately process what they have learned. We recommend that teachers review both the standards (local, state and national) and the curricula that guide their instruction to determine which of the activities provided for this set best meet their needs and those of their students. Please be aware that the activities in this guide build upon one another as they lead students towards a greater understanding of mathematics and geometric concepts.

## **Student Journals**

The students will find it helpful to keep math journals during these lessons. There are several ways that journals can be used; these are described in more detail in the lessons themselves. The students can write down any new vocabulary words that are introduced in the lessons and they record the definitions. The models can be drawn and labeled in these journals. Any questions that the students have, as they explore with K'NEX, can be recorded, as can their answers to any informal quizzes you may have them take. The journals would also be a good place for the students to write down the descriptions and the attributes of their models.

# NCTM Standards

*Concepts, skills and knowledge development correlations with the National Council of Teachers of Mathematics Standards*

rectangle

STANDARD	LESSON #	ACTIVITY
<p><b>1. Numbers and Operations</b></p> <ul style="list-style-type: none"> <li>• Understand numbers, ways of representing numbers, relationships among numbers and number systems</li> <li>iii. Develop understanding of fractions as parts of unit wholes, as parts of a collection, as locations on number lines, and as divisions of whole numbers</li> <li>iv. Use models, benchmarks, and equivalent forms to judge the size of fractions</li> </ul>	12	Patterns and Fractions
<p><b>2. Algebra</b></p> <ul style="list-style-type: none"> <li>• Understand patterns, relations, and functions</li> <li>i. Describe, extend, and make generalizations about geometric and numeric patterns</li> </ul>	12	Patterns and Fractions
<p><b>3. Geometry</b></p> <ul style="list-style-type: none"> <li>• Analyze characteristics and properties of two- and three-dimensional geometric shapes and develop mathematical arguments about geometric relationships</li> <li>i. Identify, compare, and analyze attributes of two- and three-dimensional shapes and develop vocabulary to describe the attributes</li> <li>ii. Classify two- and three-dimensional shapes according to their properties and develop definitions of classes of shapes such as triangles and pyramids</li> <li>v. Make and test conjectures about geometric properties and relationships and develop logical arguments to justify conclusions</li> <li>• Use visualization, spatial reasoning, and geometric modeling to solve problems</li> <li>i. Build and draw geometric objects</li> <li>ii. Create and describe mental images of objects, patterns and paths</li> </ul>	2; 3; 4; 5; 6; 7; 8; 9; 10; 11; 12	Lines and Angles; Triangles; Squares and Rectangles; Quadrilaterals; More 2-D Shapes; Cubes and Rectangular Prisms; Pyramids; More 3-D Shapes; 2-D and 3-D Symmetry; More Symmetry

# NCTM Standards

square

rectangle

*Concepts, skills and knowledge development correlations with the National Council of Teachers of Mathematics Standards*

STANDARD	LESSON #	ACTIVITY
<p><b>3. Geometry</b></p> <ul style="list-style-type: none"> <li>Apply transformations and use symmetry to analyze mathematical situations</li> </ul>	<p>11; 12</p>	<p>2-D and 3-D Symmetry; More Symmetry</p>
<p><b>6. Problem Solving</b></p> <ul style="list-style-type: none"> <li>Build new mathematical knowledge through problem solving</li> <li>Apply and adapt a variety of appropriate strategies to solve problems</li> </ul>	<p>2; 3; 4; 5; 6; 7; 8; 9; 10; 11; 12</p>	<p>Lines and Angles; Triangles; Squares and Rectangles; Quadrilaterals; More 2-D Shapes; Cubes and Rectangular Prisms; Pyramids; More 3-D Shapes; 2-D and 3-D Symmetry; More Symmetry</p>
<p><b>8. Communication</b></p> <ul style="list-style-type: none"> <li>Organize and consolidate their mathematical thinking through communication</li> <li>Communicate their mathematical thinking coherently and clearly to peers, teachers, and others</li> <li>Analyze and evaluate the mathematical thinking and strategies of others</li> <li>Use the language of mathematics to express mathematical ideas precisely</li> </ul>	<p>2; 3; 4; 5; 6; 7; 8; 9; 10; 11; 12</p>	<p>Lines and Angles; Triangles; Squares and Rectangles; Quadrilaterals; More 2-D Shapes; Cubes and Rectangular Prisms; Pyramids; More 3-D Shapes; 2-D and 3-D Symmetry; More Symmetry</p>
<p><b>10. Representation</b></p> <ul style="list-style-type: none"> <li>Create and use representations to organize, record, and communicate mathematical ideas</li> </ul>	<p>2; 3; 4; 5; 6; 7; 8; 9; 10; 11; 12</p>	<p>Lines and Angles; Triangles; Squares and Rectangles; Quadrilaterals; More 2-D Shapes; Cubes and Rectangular Prisms; Pyramids; More 3-D Shapes; 2-D and 3-D Symmetry; More Symmetry</p>

# Lesson 1:

# Introductory Activity

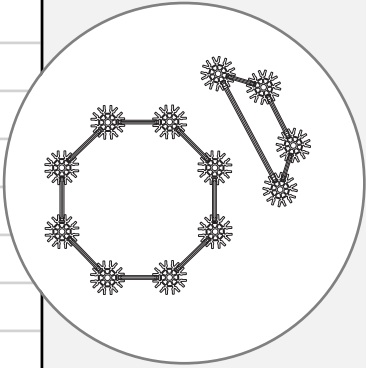

**Time**  
45 minutes – 1 hour

### Objectives

The students will be able to:

- Explore shapes using selected K'NEX pieces
- Construct as many different shapes as possible using the K'NEX pieces
- Draw the shapes using the constructed K'NEX models
- Develop vocabulary to describe the shapes

### Materials

Each group of students will need from their K'NEX Math and Geometry set:

- 24 white Connectors
- All the Rods in the set: 12 each of the red, blue and white Rods, 8 yellow Rods, 1 gray Rod

### Each student will need:

- Sheets of 8.5" x 11" paper
- Ruler and pencil
- Student Journals (optional)

### You will need:

- 1 roll of butcher paper
- Vocabulary cards (optional)

### Vocabulary

triangle, square, rectangle, rhombus, parallelogram, trapezoid, quadrilateral, pentagon, hexagon, octagon

### Teacher's Notes:

Only 1 square, rectangle, rhombus, etc. should be made by each group, even though a number of different sized squares, rectangles, rhombi, etc. can be made from the materials.

Some of the figures that the children construct may be too large for a standard 8.5" x 11" piece of paper. Have a roll of butcher paper available for the students to use for these larger figures.

You may want each member of the group to have his/her own set of shapes drawn on paper; alternatively there can be one set of drawings per group. If you decide on a group set of shapes, make sure that group members take turns recording the shapes on paper.

### Procedure:

1. Have each group of students arrange the 24 white Connectors and all the Rods from their set on their desk/working area. Instruct the students to use the pieces of K'NEX to make as many different closed, 2-D shapes as they can.
2. Once constructed, students should draw each shape using the following process:
  - Place the shape on a blank sheet of paper and hold it firmly in place.
  - Place a pencil point into the center hole of each white Connector and make a mark.
  - Remove the K'NEX shape from the paper.
  - Using a ruler, connect the dots to create the shape on paper.

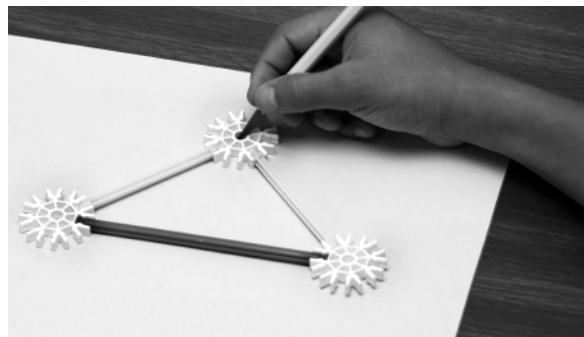

pyramid

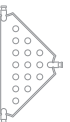

triangle

angles

90°

symmetry

p a t t e r n





line

3. Once the shapes are recorded, the students can start to identify them. They may draw on their past experience for the names, but be prepared to help students identify some of the shapes they have constructed. The students will then label their drawings.
4. You may want to introduce the vocabulary cards at this time, along with the journal. Alternatively, because this is an introductory lesson, you may want to save these for another time.
5. Review the shapes that the students may have collectively constructed and identified. The following shapes can be made from the Connectors and Rods: **triangle, square, rectangle, rhombus, parallelogram, trapezoid, quadrilateral, pentagon, hexagon, and octagon.**

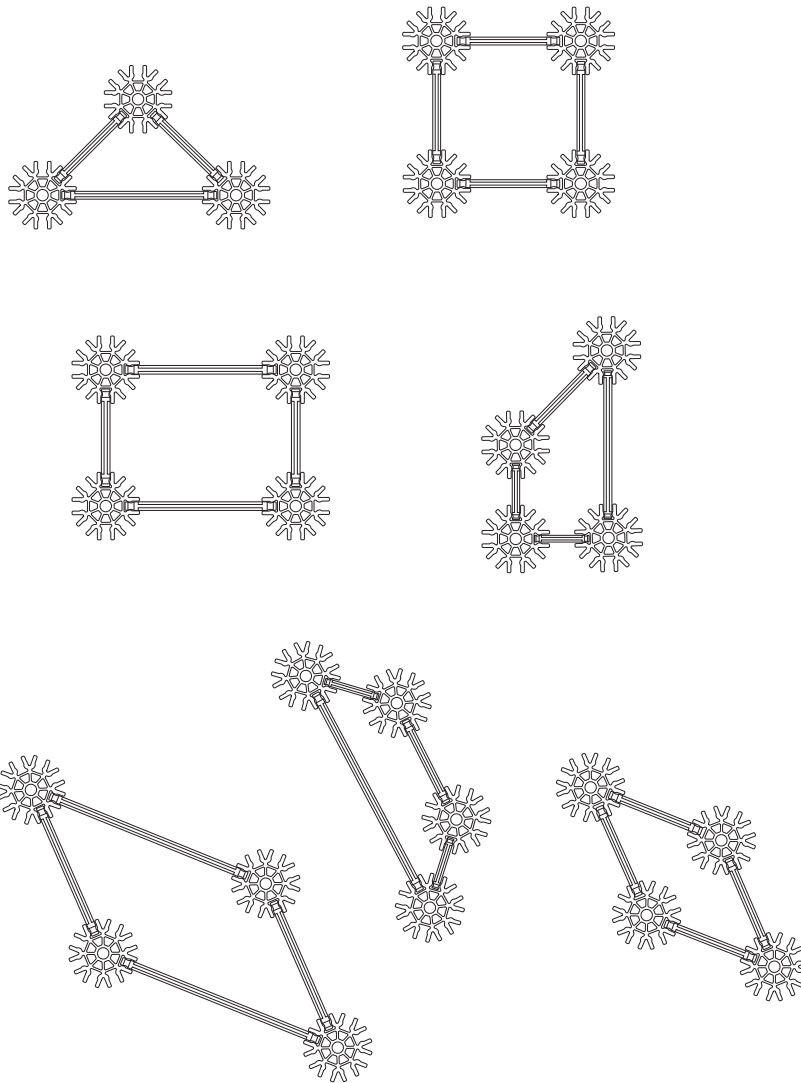

**Teacher's Notes:** There may be different sizes of many of the same figures represented in the children's drawings. These drawings can be used at a later time when you classify figures and when you discuss congruence and similarity.

rectangle

Introduction

t-square

# Introductory Activity

line

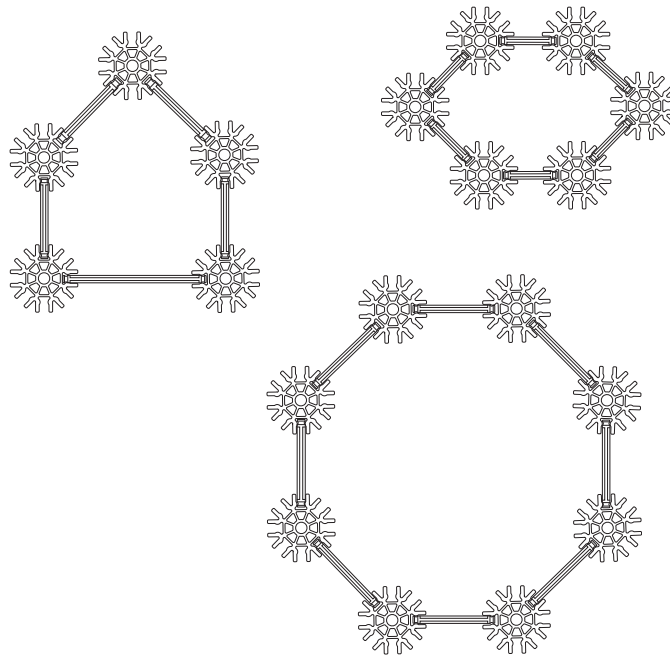

rectangle

## Assessment

The drawings should be collected so that you can check each group's ability to translate their knowledge and understanding into action. Questions to consider:

- How many different kinds of shapes did each group make?
- Did they repeat any of the shapes?
- Is each shape labeled properly?

## Extension

- How many different four-sided shapes can you make?
- Make drawings of them.
- Keep these in a folder for later use.

t-square

## Lesson 2:

# Lines and Angles

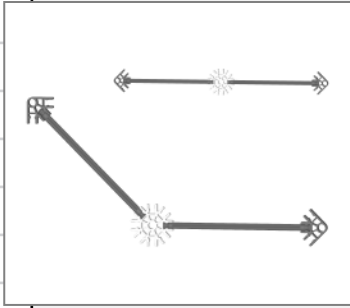

**Time**  
45 minutes – 1 hour

### Objectives

The students will be able to:

- Construct a model of a line, a line segment, and a ray
- Construct a model of a right angle, an acute angle, and an obtuse angle
- Explain the attributes of each model
- Identify each model by its attributes
- Identify each model by its name

### Materials

Each group of students will need from their K'NEX Math and Geometry set:

- 3 yellow Rods
- 10 red Rods
- 7 white Connectors
- 8 red Connectors
- 1 turquoise/black hinge Connector

• Building Instructions Booklet: Pages 2-3

### Each student will need:

- Student journal

### You will need:

- Vocabulary cards (see pages 45-72)
- Supply of paper plates (optional)
- Yarn (optional)
- Paper arrows (optional)

### Vocabulary

point, line, line segment, ray, right angle, acute angle, obtuse angle, straight angle, rotational symmetry

### Teacher's Notes:

*It is important that the students connect the yellow Rod into the center connection point of the red Connectors. There will be 3 possible arrangements, as shown in the diagrams on Page 2 of the Building Instructions booklet.*

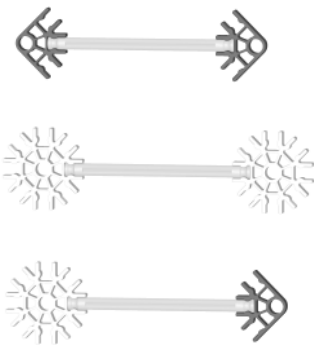

p a t t e r n

### Procedure:

1. Each group should start with all the K'NEX pieces displayed on their desk/workspace. Ask the students to select the 3 yellow Rods, 3 white Connectors, and 3 red Connectors. Using the diagrams on Page 2 of the Building Instructions as a guide, ask them to put together 1 Rod and 2 Connectors in as many different combinations as possible.

2. Have the students point out how their models are different. These differences will be the exact attributes of each model.

- They should record this information in their journals. If necessary, help the students to infer that the white Connector will stand for a point and that the red Connector will stand for an arrow.
- Go over the definitions for each model: **line**, **line segment**, **ray**. As you describe each, ask the students to hold up their model.
- Repeat this activity by saying the name of each and having the students again hold up the appropriate model.
- Set these aside and ask them to CLOSE the Building Instructions booklet.

# Lines and Angles

## Teacher's Notes:

There will be four possibilities. Please note that the students may try to tell you there are more than four, but if you can turn an angle and still have the same angle, IT IS the same angle. This is **rotational symmetry**.

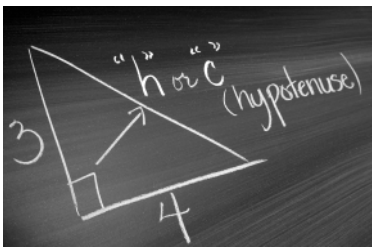
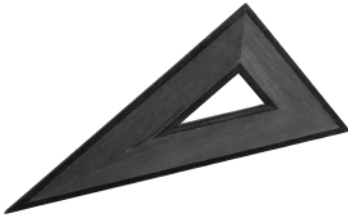

## Teacher's Notes:

We recommend laminating the vocabulary cards.

3. Invite the students select eight red Rods, four white Connectors, and eight red Connectors.

- Invite the students to put together as many different models as they can; they should use the following guidelines:
  - i. Each model is to be built from 2 red Rods, 1 white Connector, and 2 red Connectors. Suggest that they organize their materials into sets of these K'NEX pieces.
  - ii. In each model the white Connector should be in the middle, with the two red Rods connected to it.
  - iii. A red Connector must be placed on the end of each red Rod. It should be connected to the Rod using the central connection point so that it resembles an arrowhead.
  - iv. When they have completed their models ask them to compare them with the ones shown on Pages 2-3 of the Building Instructions booklet.

- Ask the students to point out how their models are different. These differences will be the exact attributes of each model.
- The students should have a journal to record this information.

4. Remind them that the white Connector stands for a point. Go over the definitions for each model: **right angle**, **acute angle**, **obtuse angle**, and **straight angle**.

- As you describe each, have the students hold up their models.
- Repeat this activity by saying the name of each and having the students again hold up the appropriate model.

5. Invite the students to take the turquoise/black hinge Connector and connect it to two red Rods. They should be able to make different angles with this arrangement.

- Ask them to make an **acute angle**, **right angle**, **obtuse angle**, and **straight angle**.
- Have them make the angles when you give the definition and also have them make the angles when you say the word.

## Assessment

1. Hold up the pre-made vocabulary cards and encourage the students to hold up the model that represents each word that you are displaying. Do a quick check of all students as they are holding up the models. If any of the students seem to be having trouble with a particular word, review the definitions and try this activity again.

pyramid

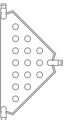

triangle

angles

90°

symmetry



2. If you would like to undertake a more formal assessment during a paper/pencil test, you can display the different models at stations around the room. Invite the students, a row at a time, to take turns visiting the stations and naming the models that are shown. Number the stations according to where you want them to place their responses on their answer sheets.



## Extension

For this activity you will need paper circles to represent points (paper plates work well), paper arrows, and yarn. Given one of the vocabulary words: **point**, **line**, **line segment**, **ray**, **obtuse angle**, **right angle**, **acute angle**, **straight angle**, the students will select the materials they need to “act out” the vocabulary word.

For example:

If the student has to demonstrate the term “**ray**”, they would need a point, an arrow, and one piece of yarn. Holding the point and one end of the yarn, the demonstrating student would need to ask for a helper to hold the arrow and the other end of the yarn. The other students would guess what they are trying to show. In this way you will be able to check the understanding of the demonstrating student(s) as well as those who are guessing.



## Line and Angle Terms for the Teacher

**Point:** An exact location in space that is usually represented by a dot. It is named with a capital letter. P is point P.

*(We will use the white K’NEX Connector to represent this.)*

**Line:** A straight path in space that extends infinitely far in both directions. There are no endpoints but it can be named using two points on the line.  $\overleftrightarrow{AB}$  is line AB, where A and B are points somewhere on the line.

*(We will use a K’NEX Rod with red Connectors on each end as arrows.)*

**Line segment:** A straight path in space that has two definite endpoints.  $\overline{AB}$  is line segment AB, where A and B are the endpoints of the line segment.

*(We will use any K’NEX Rod with white Connectors at each end as points.)*

**Ray:** A part of a line with one definite endpoint that extends infinitely in one direction.  $\overrightarrow{AB}$  is ray AB, where A is the endpoint and the line extends through B.

*(We will use any K’NEX Rod with a white Connector on one end as a point and a red Connector on the other end as an arrow.)*

# Lines and Angles

## Line and Angle Terms for the Teacher

line

**Angle:** A figure that is formed when two rays meet at a common endpoint.  $\angle A$  is angle A, where A is the common endpoint of the two rays. An angle can also be represented by three letters with the middle letter the common endpoint of the two rays and the first and last letters as points on each of the rays. For example:

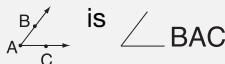

**Acute angle:** An angle whose measure is less than 90-degrees, or a **right angle**.

**Obtuse angle:** An angle whose measure is greater than 90-degrees, or a **right angle**.

**Right angle:** An angle whose measure is exactly 90-degrees.

**Straight angle:** An angle whose measure is 180-degrees, which forms a straight line.

**Rotational symmetry:** A term describing a shape that remains unchanged when it is turned less than 360-degrees about a fixed point

t-square

## Lesson 3:

# Triangles

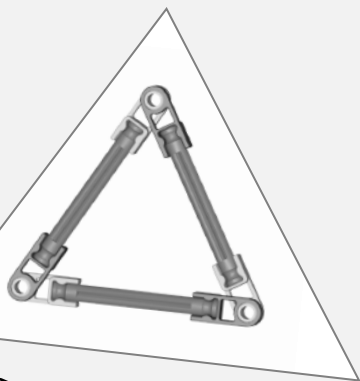

**Time**  
45 minutes – 1 hour

### Objectives

The students will be able to:

- Construct several different triangles
- Classify the triangles by their sides
- Classify the triangles by their angles

### Materials

Each group of students will need from their K'NEX Math and Geometry set:

#### For Part I:

- 3 yellow Rods
- 3 red Rods
- 3 blue Rods
- 2 white Rods
- 1 gray Rod
- 4 red Connectors
- 8 gray Connectors

#### For Part II:

- 3 blue Rods
- 3 turquoise/black hinge Connectors
- Building Instructions Booklet: Page 4

#### Each student will need:

- Student journal
- Pencil
- Sheets of 8.5" x 11" paper
- Ruler

### Vocabulary

isosceles triangles, right triangles, equilateral triangle, acute angle, right angle, hypotenuse, legs

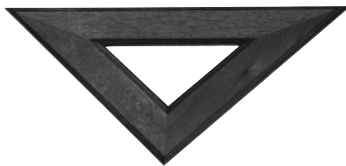
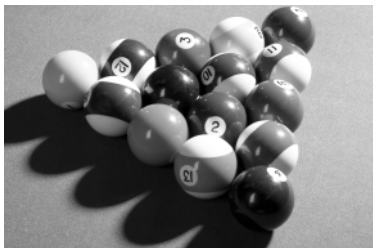

## Procedure:

### Part I

1. Ask the students to construct as many different triangles as they can, using the selected materials.

- All the pieces must be used. This discovery step may be time-consuming as the students will be building the triangles through trial and error. Since it is stipulated that all pieces **MUST** be used, they may have to disassemble some of their triangles to make this work.
- When undertaken correctly, the students will be using two gray and one red Connector for each shape.

2. After the triangles are constructed ask the students what they notice about each triangle.

- The students will find that they need two Rods of the same color and one Rod of a different color for each of the triangles.
- Use this fact to introduce new vocabulary.
- The triangles that have two Rods of the same color also have two equal sides. These are **isosceles triangles**.

p a t t e r n

Triangles

symmetry

# Triangles

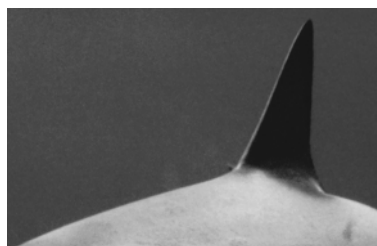
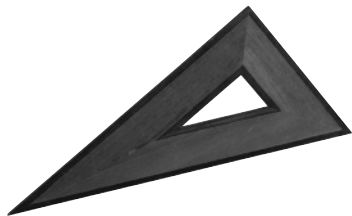

- These triangles have two equal angles also (two Connectors of the same color). Ask the students what kind of angles these are. If necessary, review the definition for acute angle.
- All of the isosceles triangles are also right triangles. Remind the students of the lesson on angles and review the definition of right angle if necessary.

3. Once constructed, students should draw each shape using the following process:

- Place the shape on a blank sheet of paper and hold it firmly in place.
- Place a pencil point into the closed hole of each Connector piece and make a mark.
- Remove the K'NEX shape from the paper.
- Connect the dots, using a ruler, to create the shape on paper.

## Part II

4. Have the students construct a triangle using the 3 blue Rods and the 3 turquoise and black hinge Connectors as shown on Page 4 of the Building Instructions.

- You may want to refer the students to the small inset photograph on Page 4 which demonstrates the correct way to combine the turquoise and black hinge Connectors.

5. Ask the students to tell how this triangle is different from the triangles in Part I.

- This triangle is made from Rods of the same color.
- The same color triangle has three equal sides. It is called an **equilateral triangle**.
- The angles are all the same size.
- Ask the students what kind of angles these are. You may have to review the definition for **acute angle**.

6. Have the students add this triangle to their collection of other triangle drawings.

7. The students should label all their drawings. Their triangles will either be **isosceles** or **equilateral triangles**.

pyramid

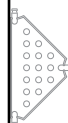

triangle

angles

90°

symmetry

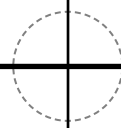





line

## Assessment

The drawings should be collected so that you can check each group's ability to translate their knowledge and understanding into action. Questions to consider:

- Did the groups find all of the possible isosceles triangles and the one equilateral triangle?
- Did they repeat any of the triangles?
- Is each triangle labeled correctly?

## Extension for Part I only:

At this point you may want to introduce the concept of similarity. All the shapes in **Part I** were isosceles triangles and yet they were different sizes. If your students drew their triangles on separate sheets of paper, you may want to ask them to try arranging and drawing all 4 triangles on the same sheet of paper. This will reinforce the concept of similarity in the different sized triangles.

You may also want to introduce new vocabulary with the isosceles triangles. Since they are all right triangles this is an opportunity for you to address the sides. The two sides of the same color are called "**legs**". The different colored side is called a "**hypotenuse**".

### Teacher's Notes:

*Do not use the Extension with Part II. Equilateral triangles are never right triangles.*

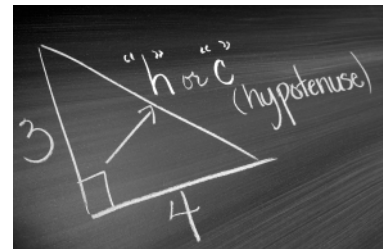

rectangle

Triangles

t-square

## Triangle Terms for the Teacher

**Right triangle:** A triangle with one right angle.

**Equilateral triangle:** A triangle with three equal angles.

**Isosceles triangle:** A triangle with two congruent sides.

**Hypotenuse:** The side in a right triangle that is opposite the right angle.

**Legs:** In a right triangle, a side that is not the hypotenuse.

**Congruence:** The relationship between two geometric shapes having the same size and shape (**congruent shapes**).

## Lesson 4:

# Squares and Rectangles

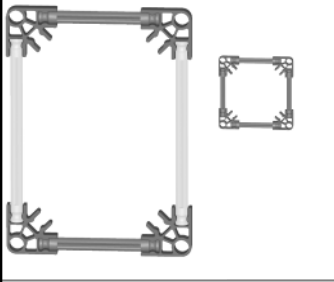

### Objectives

The students will be able to:

- Construct squares and rectangles
- Classify each four-sided figure by its attributes
- Recognize that each figure has four right angles

### Materials

Each group of students will need from their K'NEX Math and Geometry set:

- All the red Connectors
- All the Rods
- Building Instructions Booklet: Page 5

### Each student will need:

- Student journal
- Pencil
- Sheets of 8.5" x 11" paper
- Ruler
- 6 - 3x5 Cards (optional)
- Scissors (optional)

### Time

45 minutes – 1 hour

### Vocabulary

square, rectangle, right angle, congruence, similarity

### Teacher's Notes:

There are only 8 red Connectors in the set and so after building 2 four-sided shapes they will have to disassemble their models. Remind the students that they will need to draw each shape before it is disassembled.



### Procedure:

1. Ask the students to construct as many different four-sided, closed figures as they can with the materials provided.
2. Once constructed, students should draw each shape using the following process:
  - Place the shape on a blank sheet of paper and hold it firmly in place.
  - Place a pencil point into the closed circle of each red Connector and make a mark.
  - Remove the K'NEX shape from the paper.
  - Connect the dots, using a ruler, to create the shape on paper.
3. They will discover that although the sizes of the shapes are different, there are only two basic shapes that can be constructed: a **square** and a **rectangle**. They should be able to note the unique characteristics of each in their journals.
4. Ask the students to point out what is the same in all the figures, no matter what Rods were used in their construction. They should be able to identify that all four angles are the same - they are all **right angles**.

pyramid

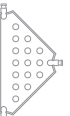

triangle

angles

90°

symmetry



line

5. Since all the groups now have squares and rectangles in front of them, it would be a good time to discuss **congruence** and **similarity**.

- Introduce the definition for each and then have the students test their models for congruence by either placing their models on top of other students' models or by placing both models on top of each other on the overhead projector. Either way should show that the models are exactly the same.
- Similar figures can be discussed by noting the same angles but with different colored rods for the sides. They can compare their models with those shown on Page 5 of the Building Instructions. (*Caution: Not every rectangle is similar to every other rectangle. They must be proportional.*)
- Students can also use their papers from the introductory lesson and try to find other congruent and similar figures.

## Assessment

Ask the students to prepare two sheets of paper, one labeled: **SQUARE** and the second labeled: **RECTANGLE**. Have them list five characteristics of each type of figure on the appropriate sheet of paper. This will show you if they understand the characteristics of each. It will also demonstrate their creativity.

## Extension

1. Take all the assessment papers and start two new posters. One poster will have the title **SQUARES**; the other will be labeled **RECTANGLES**.
  - Record the unique characteristics of each on the appropriate poster. These are the characteristics that the students identified during the assessment phase.
  - Explain that the posters are a “work in progress” because if they can think of any other characteristics, these can be added to the poster. You will be surprised by what the students can discover about the shapes.
  - You can use these posters as the centerpiece of a mathematics bulletin board.
2. Give the students **six** same-sized paper rectangles. (3 x 5 cards work well.)
  - Have the students draw a diagonal on each card and then cut each rectangle on the diagonal.
  - Next, have the students reassemble the rectangles to form as many different shapes as possible. The one rule is that each piece must touch one complete side of another piece.

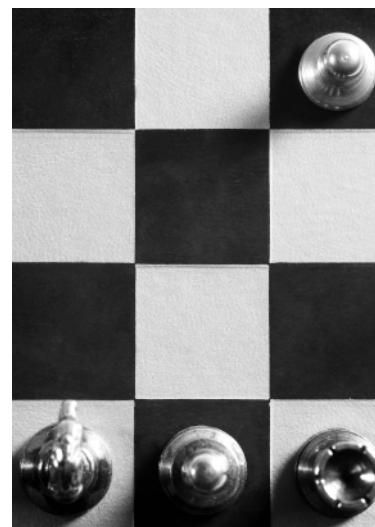

rectangle

Squares and Rectangles

t-square

# Squares and Rectangles

- All of the possibilities are as follows:

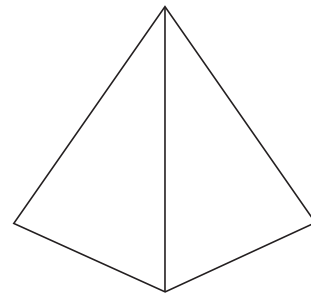
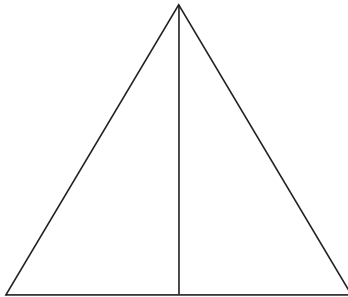
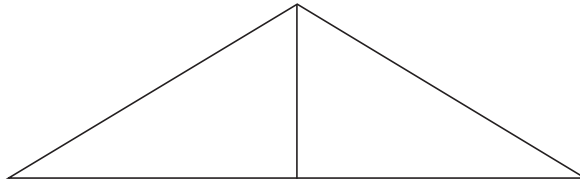
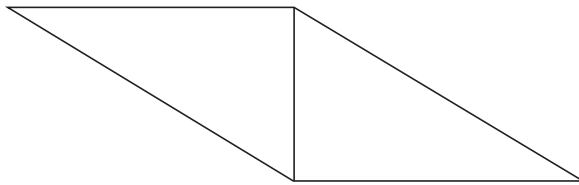
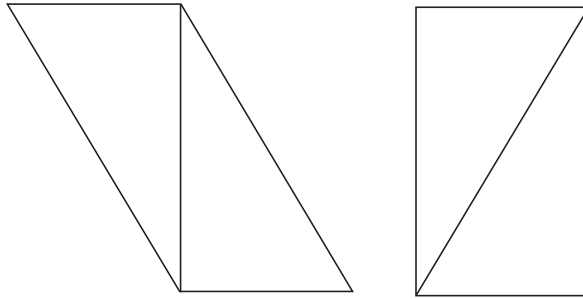
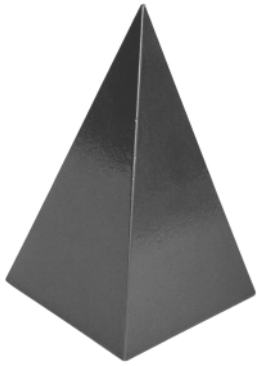
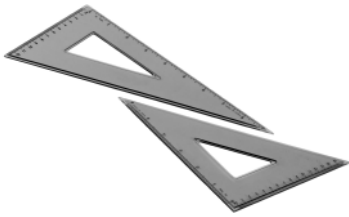

- When the students have found all of the possibilities, they can glue them onto separate sheets and record the attributes of each.
- Even though some of the shapes have not yet been discussed, they will be able to describe them. Since some of the shapes will be triangles, you can check their retention of previously learned concepts.
- You will be able to see how many mathematical terms they are comfortable using.

pyramid

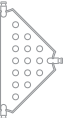

triangle

p a t t e r n

angles

90°

symmetry

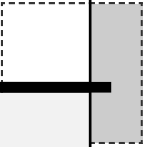

## Square and Rectangle Terms for the Teacher

**Square:** A closed figure with four equal sides and four equal (right) angles.

**Rectangle:** A closed figure with four sides, whose opposite sides are equal and with four equal (right) angles.

**Right angle:** An angle whose measure is exactly 90-degrees.

**Similar shapes:** Two shapes that have the exact same shape—corresponding angles that are congruent and corresponding sides that are proportional.

**Congruence:** The relationship between two geometric shapes having the same size and shape (**congruent shapes**).

# Lesson 5:

# Quadrilaterals

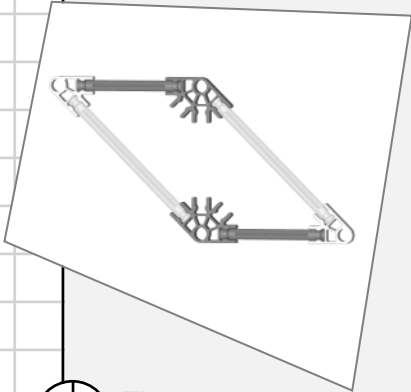

**Time**  
45 minutes – 1 hour

### Objectives

The students will be able to:

- Construct models of four-sided figures
- Explain the attributes of each model
- Identify each model by its attributes
- Identify each model by its name

### Materials

Each group of students will need from their K'NEX Math and Geometry set:

- 4 white Rods
- 6 blue Rods
- 7 yellow Rods
- 7 red Rods
- 7 gray Connectors
- 6 red Connectors
- 7 green Connectors
- 4 turquoise/black hinge Connectors
- Building Instructions Booklet: Page 6-7

### Each student will need:

- Student journal
- Pencil
- Sheets of 8.5" x 11" paper
- Ruler

### You will need:

- Vocabulary cards (optional)

### Vocabulary

quadrilateral, parallelogram, trapezoid, rhombus, square, rectangle



### Procedure:

1. Help the students to understand that not all 4-sided figures are squares or rectangles.

- Ask them to look at the photographs on Page 6 of the Building Instruction booklet.
- Encourage volunteers to draw the shape of the trowel and the shape of the xylophone on the chalkboard.
- How do these shapes differ from the square and the rectangle? How are they the same?

2. Each group should start with all of the K'NEX Rods and Connectors arranged on the desk/workspace.

- Ask them to build as many different four-sided shapes as possible. All the pieces of K'NEX identified in the materials list must be used.
- You may want to ask the students how many different shapes they can make at this time. You may have students who can calculate that each group can make six different shapes: 24 Rods divided by 4 Rods per figure will equal 6 figures. This discovery step may take some time, as the students will be building the shapes using trial and error strategies.

pyramid

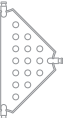

triangle

p a t t e r n

angles

90°

symmetry

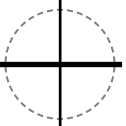



line

- Since it is stipulated that all pieces **MUST** be used, they may have to disassemble some of their quadrilaterals to make this work. You may have students make several parallelograms. This is acceptable. You can remind them in the next step about similar figures.
- The possible figures to make are: **quadrilateral, trapezoid, parallelogram, rhombus, rectangle, and square.**

3. After the quadrilaterals are completed, have the students meet as a whole.

- Ask a member of the first group to hold up one of their figures. Have the other groups look at this figure and see if they can find a figure in front of them that has the same attributes. For example: rectangles have two pairs of parallel sides, with opposite sides equal and four right angles.
- As you check, respond to each group. If a student holds up a dissimilar figure have them try again. Remember, not all of the groups will find all of the possible shapes. Have the students put these shapes to one side.
- Call on another group and repeat the steps above. Do this until all of the shapes have been recognized.
- When they display the figure that uses the turquoise/black Connectors, it may be easier for the other students to “visit” that group’s station. At this time you may want to discuss **similar** figures again.

4. Once the groups have shown the shapes, students should draw each shape using the following process:

- Place the shape on a blank sheet of paper and hold it firmly in place.
- Place a pencil point into the closed hole of each Connector piece and make a mark.
- Remove the K’NEX shape from the paper.
- Connect the dots, using a ruler, to create the shape on paper.
- Remind them to be very careful with the shape that uses the turquoise/black Connectors.
- If one group found a figure that no other group discovered, ask them to share their shape with the other students—they can physically give the other groups their shape to trace, or the other groups can disassemble some shapes that have already been traced and construct a similar model of their own.

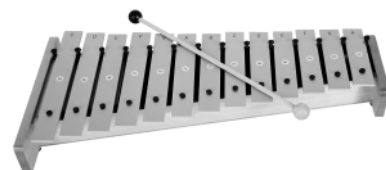

rectangle

Quadrilaterals

t-square

**Teacher’s Notes:**

*Some of the figures that the children construct may be too large for a standard 8.5" X 11" piece of paper. Have a roll of butcher paper available for these larger models.*

# Quadrilaterals

rectangle

line

5. Once all the shapes have been drawn, it is time to identify them.
  - Using the vocabulary cards, introduce, or reintroduce if you did this in the introductory activity, the name and the definition of each new shape.
  - The students can record these definitions in their journals. Once this step is completed, the students can identify their models - they may have to be reconstructed if this step is undertaken on a different day. This is suggested because of the time the first three steps will take.
6. Ask the students to look at the photos and the models on Pages 6-7 of the Building Instructions booklet. Can they identify the quadrilaterals in the pictures?
7. Once you are confident that the students can identify the different figures (their own models and those in the booklet), have them return to their drawings and label them.

## Assessment

1. You will be assessing the students throughout the first three steps in the procedure by visually checking their models and offering immediate and specific feedback to each group. You will be able to assess their understanding of these quadrilaterals by collecting their drawings and checking to see if they are labeled correctly.
2. If you would like to undertake a more formal assessment during a paper/pencil test, you can arrange the different models at stations around the room. Invite the students, a row at a time, to take turns visiting the stations and naming the models that are shown. Number the stations according to where you want the students to place their responses on their answer sheets.

## Quadrilateral Terms for the Teacher

**Quadrilateral:** Any four-sided, closed figure.

**Trapezoid:** A quadrilateral with exactly one pair of parallel sides.

**Parallelogram:** A quadrilateral with opposite sides that are equal and parallel.

**Rhombus:** A parallelogram with four congruent sides.

**Square:** An equilateral and equiangular quadrilateral. (OR: A closed figure with four equal sides and four equal (right) angles.)

**Rectangle:** A quadrilateral with all interior right angles.

t-square



## Lesson 6:

# More 2-D Shapes

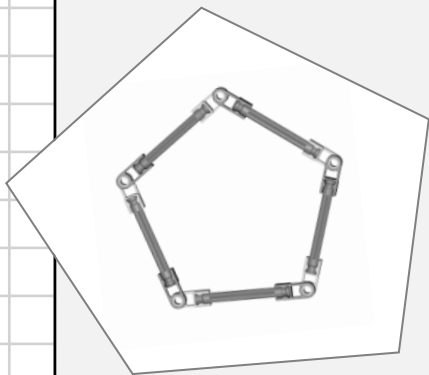

**Time**  
45 minutes – 1 hour

### Objectives

The students will be able to:

- Build closed figures that have more than 4 sides
- Explain the attributes of each built model
- Identify each model by its attributes
- Identify each model by its name

### Materials

Each group of students will need from their K'NEX Math and Geometry set:

- All the Rods
- All the white, red, green and turquoise/black Connectors
- Building Instructions Booklet: Page 8

### Each student will need:

- Sheets of 8.5" x 11" paper
- Ruler and pencil
- Student Journals (optional)

### You will need:

- 1 roll of butcher paper
- Vocabulary cards (optional)

### Vocabulary

pentagon, regular pentagon, hexagon, regular hexagon, octagon, regular octagon.



p a t t e r n

### Procedure:

1. Have the groups of students arrange all the selected K'NEX pieces on their desk/workspace.
2. Ask the students to look at the photograph of the soccer ball on Page 8 of the Building Instructions booklet.
  - Ask how many different shapes they can identify in the ball. Expect the students to identify two shapes: the black shapes are 5-sided figures and the white shapes are 6-sided figures.
  - Ask if anyone knows the names given to the shapes they have identified.  
Answers: 5-sided = **pentagon**; 6-sided = **hexagon**.
3. Suggest the students construct the two shapes that are found in the soccer ball.
  - They can follow the building instructions on Page 8 for the pentagon and adapt the hexagon by using blue Rods only instead of the yellow and red Rods shown in the diagram.
  - You may want to invite two or more groups to try to combine their figures and reproduce the arrangement shown in the soccer ball.
4. Invite the students to make as many shapes as they can with five, six or eight sides. They may use all their Rods and Connectors.
  - Challenge them to build an 8-sided shape that is not similar to the one shown on Page 8 of the Building Instructions.

More 2-D Shapes

symmetry

# More 2-D Shapes

## Teacher's Notes:

Some of the figures constructed by the students may be too large for a standard 8.5" X 11" piece of paper. Have a roll of butcher paper available for these larger models.



5. Once the groups have built the shapes they should draw each one using the following process:

- Place the shape on a blank sheet of paper and hold it firmly in place.
- Place a pencil point into the closed hole of each Connector piece and make a mark.
- Remove the K'NEX shape from the paper.
- Connect the dots, using a ruler, to create the shape on paper.
- Remind them to be very careful with the shape using the turquoise/black Connectors because the Connectors may move.

6. At this point you should introduce/reintroduce the new vocabulary: **pentagon, regular pentagon, hexagon, regular hexagon, octagon, regular octagon.**

- As you review these words have the students match up their models with the vocabulary word that is introduced.
- Ask the students to point out what makes the **regular** figures regular. This should become obvious to them because all of the sides in a **regular** figure are made from Rods of the same color (the sides are equal in length) and all the angles are equal.

7. Once the students have entered the vocabulary into their journals, ask them to correctly label their drawings. Caution them to be mindful of labeling the figures as **regular** or not.

8. Once again, you can discuss the concepts of **similarity** and **congruence**. (See Step 5 under "Procedure" from the Squares and Rectangles lesson).

## Assessment

1. Display pre-made vocabulary cards, one at a time, and have the students hold up the model that is represented by the term on the card. Undertake a quick check of all the students as they are holding up the models. If any of the students seem to be having trouble with a particular word, review the definitions and try this activity again.

2. Ask the students to look at the photos and the models on Page 8 of the Building Instructions booklet. Can they correctly identify the shapes in the pictures?

3. If you would like to undertake a more formal assessment during a paper/pencil test, you can display the different models at stations around the room. Invite the students, a row at a time, to take turns visiting the stations and naming the models that are shown. Number the stations according to where you want the students to place their responses on their answer sheets.

pyramid

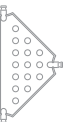

triangle

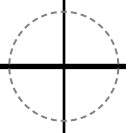



line

rectangle

## Extension

Prepare index cards with pictures of the following on one side and with the name of the figure on the other:

**pentagon, regular pentagon, hexagon, regular hexagon, octagon, regular octagon, acute triangle, obtuse triangle, right triangle, isosceles triangle, equilateral triangle, quadrilateral, trapezoid, parallelogram, rectangle, rhombus, square**

1. Working in pairs and taking turns: One student selects a card without his/her partner seeing which one. With their backs to each other, the student with the card describes the figure to the other student. The second student will then try to **build** or draw the figure that is described. (Note: the student with the card may NOT say the name of the figure at any time during the description).

2. Working in pairs and taking turns: One student selects a card without his/her partner seeing which one. With their backs to each other, the second student asks questions about the figure on the card. The student with the card may only answer the questions with a "Yes" or "No" answer. Ask the students to keep track of how many questions it takes before they guess the identity of the figure.

More 2-D Shapes

## More 2-D Shapes Terms for the Teacher

**Polygon:** A simple closed shape composed of a finite number of line segments, each of which intersects exactly two of the other segments, one at each endpoint.

**Pentagon:** A polygon with five sides.

**Regular pentagon:** A polygon with five congruent sides and five congruent angles.  
*(For this model, all the sides will be constructed from Rods of the same color.)*

**Hexagon:** A polygon with six sides.

**Regular hexagon:** A polygon with six congruent sides and six congruent angles.  
*(For this model, all the sides will be constructed from Rods of the same color.)*

**Octagon:** A polygon of eight sides.

**Regular octagon:** A polygon of eight congruent sides and eight congruent angles.  
*(For this model, all the sides will be constructed from Rods of the same color.)*

t-square

# Cubes and Rectangular Prisms

## Lesson 7:

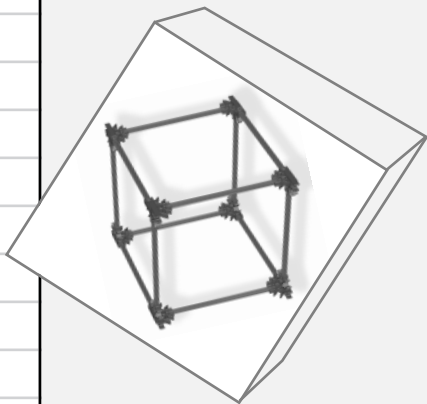

**Time**  
45 minutes – 1 hour

### Objectives

The students will be able to:

- Construct a cube
- Construct a rectangular prism
- Determine the attributes of cubes and rectangular prisms
- Use vocabulary correctly when speaking and writing about cubes and rectangular prisms.
- Identify vertices, edges, and faces

### Materials

Each group of students will need from their K'NEX Math and Geometry set:

- All the Rods
- All the purple Connectors
- Building Instructions Booklet: Page 9

### Each student will need:

- Student journal

### You will need:

- Vocabulary cards (optional)

### Vocabulary

cube, rectangular prism, edge, vertex, vertices, face



### Procedure:

1. Ask the students to look at the two photographs on Page 9 of the Building Instructions booklet and explain how the shape of the wrapped gift differs from the shape of the wooden bench.

- The images of the K'NEX models may help them determine some of the differences. They will probably suggest that the sides in the “gift” shape are of equal length, while those of the bench have opposite sides that are equal, or the bench shape is longer than the gift shape.
- You may want to introduce the terms **cube** and **rectangular prism** at this point; alternatively, introduce them after they have constructed their models.

2. Invite the groups of students to construct the **cube** shown on Page 9 of the Building Instructions booklet using the red Rods and the purple Connectors.

- Make sure every student is able to correctly join two purple Connectors – you may need to remind them to check the small inset diagrams on Page 9.

3. Introduce the vocabulary words: **edge**, **vertex**, **face**, (and **cube**).

- Have the students identify each on their model. The red Rods will be the **edges**, the purple Connectors will be the **vertices**, and the squares that they form will be the **faces**.

pyramid



triangle

p a t t e r n

angles

90°

symmetry



4. Ask the students to record these words in their journals with their definitions.

- Have the students describe each of the faces of the cube. They should be able to tell you that each is a square.

5. It will be necessary for the groups to disassemble the cube before they can build the **rectangular prism**.

- They will need 4 red Rods, 4 blue Rods, and the purple Connectors to construct this shape. (See: Page 9 of the Building Instructions.)

6. Have the students identify the **edges**, the **vertices**, and the **faces** of the rectangular prism.

- Ask the students to describe the faces of the rectangular prism. They should be able to tell you that two of the faces are squares and four are rectangles.

7. Encourage the students to make other cubes and prisms that are similar to the original ones they built.

- Have them discover if all of the cubes have six square faces and if all of the rectangular prisms have two square and four rectangular faces.

## Extension

1. It is possible to build a triangular prism with 4 blue Rods, 2 yellow Rods, 3 red Rods, and 6 blue and 6 purple Connectors. Have the students put the blue and purple Connectors together. Instruct them to build a triangular prism. You may want to show them a picture of a triangular prism before they begin building.

Ask: What will the faces look like? How many faces will there be?

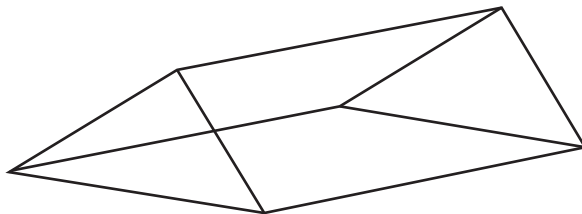

### Teacher's Notes:

*The edges of the triangular faces will be made with two blue Rods and one yellow Rod. Insert the blue Rods into the blue Connectors at a point that is closest to the purple Connector. The yellow Rod will also be connected into the blue Connector, but in the center connection spot. Once the two triangles are constructed, the red Rods should be connected into the center connection point of the purple Connectors, joining the two triangles at their vertices. (All the purple Connectors will face each other - three on one triangle and three on the other.)*

# Cubes and Rectangular Prisms

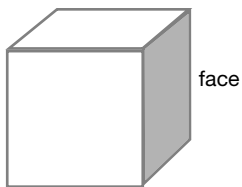
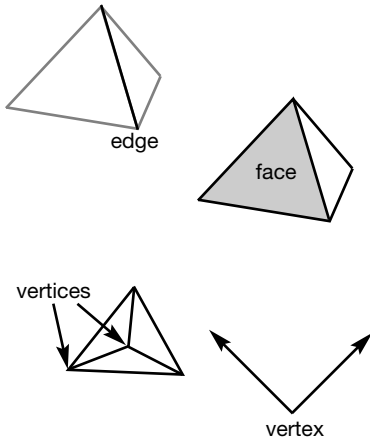
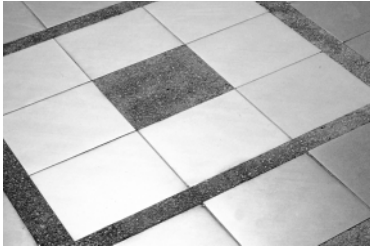

2. Think about the cube. If it rests on one of the faces and if you “unfolded” the remaining sides, this is what the resulting picture would look like:

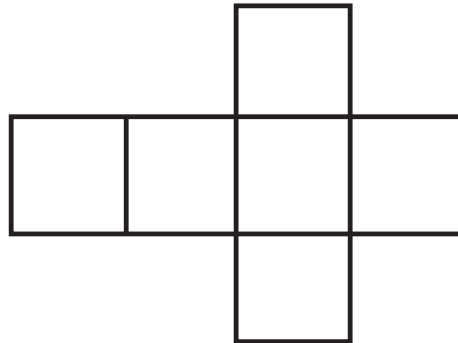

Are there any more possible patterns that could be a cube when it is “unfolded”? The pattern above is called the **net** of the cube.

POSSIBLE SOLUTIONS:

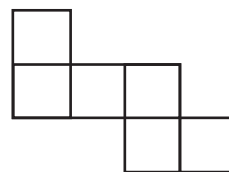
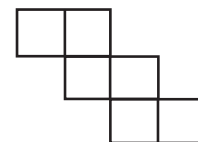
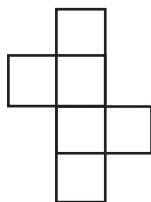
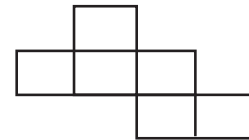
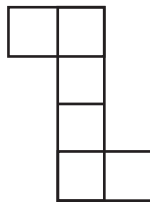
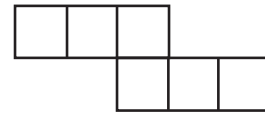
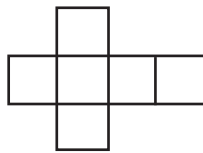
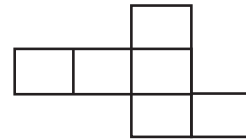
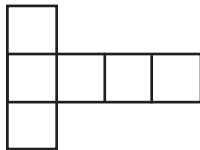

pyramid  
triangle

p a t t e r n

angles

90°

symmetry



## Cubes and Rectangular Prisms Terms for the Teacher

**Polyhedron:** A simple, closed, three-dimensional shape formed by plane polygons.

**Cube:** A regular polyhedron composed of six congruent squares.

**Rectangular prism:** A polyhedron that has two congruent parallel faces and a set of parallel edges that connects corresponding vertices of the two faces.

**Vertex:** The point where two rays forming an angle meet; the point where two sides of a polygon meet; or the point where three or more faces of a polygon meet.

**Vertices:** Plural of vertex.

**Edge:** The line of a three-dimensional shape where two plane faces meet.

**Face:** One of the plane surfaces of a polyhedron bounded by edges.

**Net:** A pattern that can be cut out, folded and glued together to make a three-dimensional model of a solid.

# Lesson 8:

# Pyramids

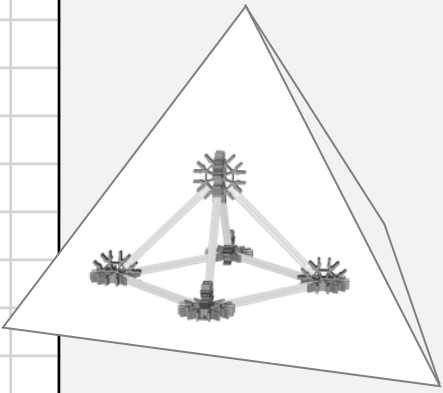

**Time**  
45 minutes – 1 hour

### Objectives

The students will be able to:

- Construct pyramids
- Use vocabulary terms correctly when speaking and writing
- List the attributes of a pyramid
- Identify vertices, edges, and faces

### Materials

Each group of students will need from their K'NEX Math and Geometry set:

- 3 red Rods
- 7 yellow Rods
- All the purple and blue Connectors
- Building Instructions Booklet: Page 10

### Each student will need:

- Student journal

### You will need:

- Vocabulary cards (optional)

### Vocabulary

vertex, vertices, edge, face, base, pyramid, triangular pyramid, square pyramid



### Procedure:

1. Ask the students to look at the photographs on Page 10 of the Building Instructions booklet.

- Most will be familiar with the term “pyramid” as it relates to the structures built in Ancient Egypt.
- Encourage them to look for less obvious examples of pyramid shapes in the classroom and at home. You can draw their attention to the pyramid shape of the tripod shown on Page 10.
- Can the students identify any difference between the shape of the pyramid structures in the photo of Egypt and the shape of the pyramid formed by the legs of the tripod? (Possible Answer: One has 3 faces, the other has 4 faces.)

2. Ask the students to construct the yellow and red pyramid shown on Page 10 of the Building Instructions booklet. You may want the groups to follow these steps:

- Make 4 sets of purple/purple Connectors.
- Make a triangle using the red Rods and 3 of the purple Connectors.
- Connect the yellow Rods to the purple Connectors so that they meet in the center and are connected to the last set of purple Connectors.
- The resulting 3-dimensional figure is a **pyramid**. Because it is resting on one face, that face is called a base. Because the **base** is a triangle, this new figure is called a **triangular pyramid**.

pyramid

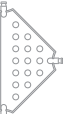

triangle

p a t t e r n

angles

90°

symmetry





line

3. Have the students identify the **vertices**, the **edges**, the **faces**, and the **base**.

Ask:

- What shapes do the faces make?
- What shape is the base?

4. Before building the other pyramid shown on Page 10, the groups of students will need to disassemble the triangular pyramid. They should refer to the Building Instructions and construct the second pyramid using the following steps:

- Make four sets of blue/purple Connectors and one set of blue/blue Connectors.
- Using the blue/purple Connectors, construct a square using four yellow Rods.
- With four additional yellow Rods, connect these yellow Rods to the purple part of each blue/purple Connector so that they meet in the center and are connected to the blue/blue Connector.

5. The figure they have constructed is also a **pyramid**.

- Have the groups of students identify the vertices, the edges, the faces, and the base.
- What polygons do the faces represent?
- What shape is the base?
- Since the base is a square, what is this called?  
**(Square pyramid.)**

## Assessment

In their journal, have the students describe either a triangular or square pyramid. They should be able to list the pyramid's attributes. Ask them to use vocabulary words in their descriptions. Look for them to mention edge, face, vertex, and base.

## Extension

Can you draw a **net** for each pyramid?

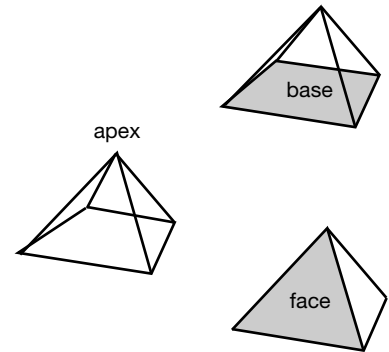

rectangle

Pyramids

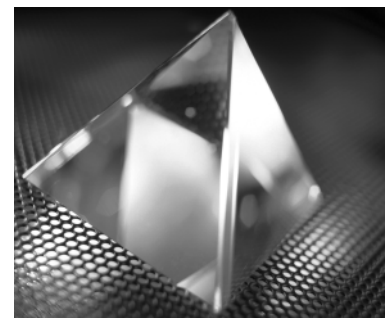
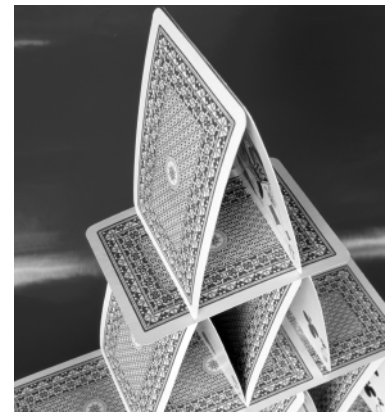

t-square

# Pyramids

## Pyramid Terms for the Teacher

**Polyhedron:** A simple, closed, three-dimensional shape formed by plane polygons.

**Pyramid:** A polyhedron that has one base and a set of edges that meet at a single point (apex) that is not in the base; all faces except the base MUST be a triangle; the base MAY be a triangle.

**Triangular pyramid:** A pyramid with a triangular base.

**Square pyramid:** A pyramid with a square base.

**Vertex:** The point where two rays forming an angle meet; the point where two sides of a polygon meet; or the point where three or more faces of a polygon meet.

**Vertices:** Plural of vertex.

**Edge:** The line of a three-dimensional shape where two plane faces meet.

**Face:** One of the plane surfaces of a polyhedron bounded by edges.

**Base:** The side of a shape used as its foundation; the face of a solid used as its foundation.

**Apex:** The point, off the base of a pyramid, where the triangular faces meet.

**Net:** A pattern that can be cut out, folded and glued together to make a three-dimensional model of a solid.

rectangle

line

t-square

## Lesson 9:

# More 3-D Shapes

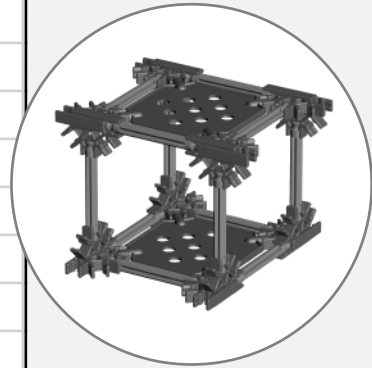

**Time**  
45 minutes – 1 hour

### Objectives

The students will be able to:

- Build a cube and a pyramid
- Identify the edges, vertices, and faces
- Use vocabulary associated with 3-D shapes
- Place solid faces on each model

### Materials

Each group of students will need from their K'NEX Math and Geometry set:

- All the blue Rods
- All the yellow Rods
- All the purple Connectors
- All the solid black Panels (6 squares and 3 triangles)
- Building Instructions Booklet: Page 11

### Each student will need:

- Student Journals (optional)

### You will need:

- Vocabulary cards (optional)

### Vocabulary

cube, triangular pyramid, hexagonal pyramid, attributes, faces, edges, vertices



### Procedure:

1. With this activity you may want to discuss the names of these shapes after the students have completed their models and examined the attributes of each.

2. Have the groups of students construct the framework of the **cube** with the top and bottom panels, as shown on Page 11 of the Building Instructions booklet.

- They will need 12 blue Rods, 8 sets (16 pieces) of purple/purple Connectors and two black Panels for this step.
- Ask the students to pay careful attention to the positioning/orientation of the purple Connectors.
- Then have the students place the 4 side Panels onto the cube. Advise the students that each side Panel has only two connection points. (See note in the Building Instructions booklet.)
- Ask them to examine the completed shape and make observations about its attributes. (Possible answers: It has 6 faces, 12 edges, and 8 vertices. It remains the same no matter what face is the base.)
- Ask for volunteers to provide the name of the shape they have built. (**Cube.**)
- Have the students record their findings in their journals.

# More 3-D Shapes



- Invite the groups of students to construct the **triangular pyramid** shown on Page 11 of the Building Instructions booklet.
  - They should first construct the frame using the yellow Rods and purple Connectors.
  - Then have the students place the 3 triangular panels onto the pyramid. Please note that the base will not have a Panel. Advise the students that one of the Panels has only two connection points. (See note in the Building Instructions booklet.)
  - Have the students examine the completed pyramid. Ask them to make observations about the shape and suggest a name for this shape. (**Triangular pyramid.**)
  - Ask the students to record their findings in their journals.
- Challenge the students to use the pieces in their set to construct a triangular pyramid that is larger, or smaller, than the one in the Building Instructions booklet.
  - Students should indicate all of the possible triangular pyramids that can be made from the pieces in their set. This information could be summarized in a simple table. (Note: Alert the students to the fact that the black panels will not fit other pyramids that they build. They can, however, insert Rods to represent the lower edges of their triangular pyramids.)

## Assessment

- Have the students write down **cube** and **triangular pyramid** in their journals. Then have them record the number of **faces**, **vertices**, and **edges** of each.
- Ask them to describe, in writing, a **hexagonal pyramid**. If they understand the attributes of pyramids they will describe the following:
  - It is a solid figure with a six-sided base (which is a hexagon)
  - It has six triangular faces that will all meet at one vertex.

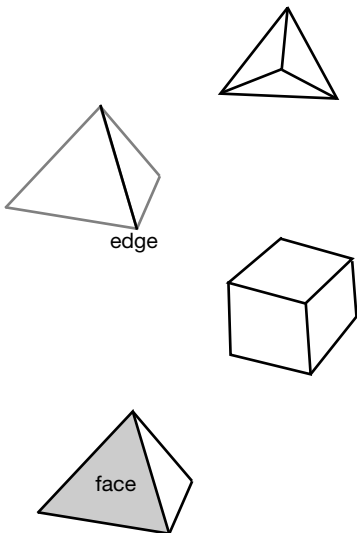

pyramid

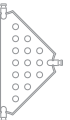

triangle

p a t t e r n

angles

90°

symmetry



## More 3-D Shapes Terms for the Teacher

**Polyhedron:** A simple, closed, three-dimensional shape formed by plane polygons.

**Cube:** A rectangular polyhedron composed of six congruent squares.

**Triangular prism:** A polyhedron that has two congruent parallel triangular faces and a set of parallel edges that connect corresponding vertices of these two triangular faces.

**Vertex:** The point where two rays forming an angle meet; the point where two sides of a polygon meet; or the point where three or more faces of a polygon meet.

**Vertices:** Plural of vertex.

**Edge:** The line of a three-dimensional shape where two plane faces meet.

# Lesson 10:

# 2-D & 3-D Symmetry

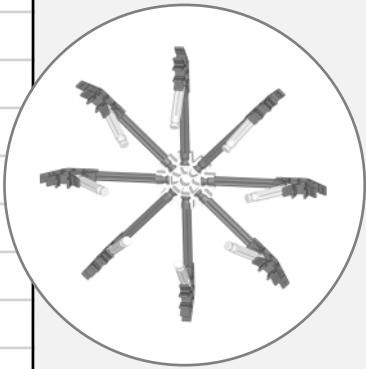

**Time**  
45 minutes – 1 hour

### Objectives

The students will be able to:

- Construct the models as shown
- Tell how each of the models is symmetrical
- Recognize lines of symmetry
- Use terms associated with symmetry in their speaking and writing
- Construct their own symmetrical models

### Materials

Each group of students will need from their K'NEX Math and Geometry set:

- 8 blue Rods
- 8 white Rods
- 4 yellow Rods
- 1 purple and 1 blue Connector
- 8 green Connectors
- 4 red Connectors
- 1 white Connector
- Building Instructions Booklet: Page 12

### Each student will need:

- Student journal
- Ruler and pencil
- Sheets of 8.5" x 11" paper (optional)
- Scissors (optional)
- Their drawings from the Introductory activity (optional)

### You will need:

- Vocabulary cards (optional)

### Vocabulary

symmetry, line of symmetry

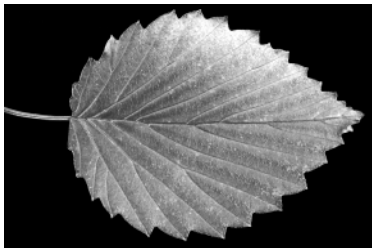

## Procedure:

### PART I

1. Have the students construct the model, shown on Page 12 (bottom left) of the Building Instructions, that uses blue and white Rods and green Connectors.

- Ask them to make sure that the green Connectors are standing up.
- Ask: What do you notice about this model?
- After the students have had a chance to discuss and record what they observe about the model, have a full class discussion.
- Help them to discover how their observations can lead them to the concept of **symmetry**. The photographs on Page 12 of the Building Instructions booklet might be used to reinforce the concept.
- Ask the students to record the word **symmetry** and its definition in their journals.

pyramid

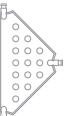

triangle

p a t t e r n

angles

90°

symmetry

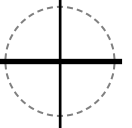



line

2. Ask the students to see if they can move any of the “arms” of this model so that it remains symmetrical.
  - There will be several ways that this can be done. Ask them to defend why their figures are symmetrical so that you can check their understanding of symmetry.

Part II

- Ask the students to build the other model on Page 12.
- Have them describe what makes this model symmetrical.
  - Suggest that the students add pieces to the model so that it is still symmetrical.
  - Ask each group of students to share their new models with the others and to explain why their new model is symmetrical.

### Assessment:

Prepare a number of figures using the K’NEX pieces. Construct some that have lines of symmetry in them and others that do not. Place the figures around the room at different stations. Assign a number to each model. Give the students each a sheet of paper with corresponding numbers on it. The students should visit each of the stations and record whether the model is symmetrical or not symmetrical.

### Extension:

1. Ask the students to go back to their drawings from the Introductory Activity where they constructed closed, 2-D shapes (see Page 3 of this Guide). Have them test each of their figures to see if they are symmetrical. Using a ruler, have the students draw **lines of symmetry** onto the figures.
2. Students can reconstruct the figures from the Introductory Activity, redraw them following the established procedure, and then cut out the figures. Once they have them cut, they can fold the figures along the lines of symmetry to prove that both sides match.
3. Ask the students to describe a symmetrical figure to a partner. Since the students know ahead of time that the figure is symmetrical, their partner will describe only one half of the figure. They must tell their partner whether they are describing the right or the left half. Once the half is described, the other half of the picture must be drawn. Then the person who described the figure will reveal that figure to his/her partner. How well was the figure described? Did the person make the drawing symmetrical?

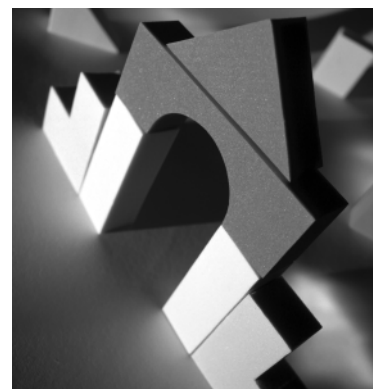

rectangle

2-D & 3-D Symmetry

t-square

# 2-D & 3-D Symmetry

## 2-D & 3-D Symmetry Terms for the Teacher

**Symmetry:** Correspondence in size, shape, and relative position of parts on opposite sides of a dividing line, or median plane, or about a center, or axis.

**Line of symmetry:** A line that divides a shape into congruent halves.

rectangle

line

t-square



## Lesson II:

# More Symmetry

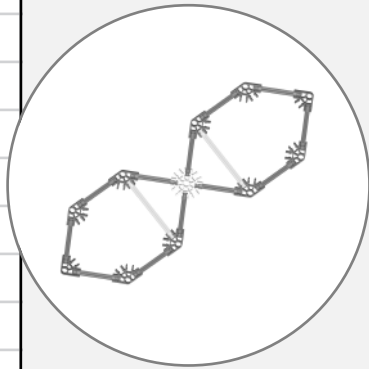

**Time**  
45 minutes – 1 hour

### Objectives

The students will be able to:

- Construct symmetrical models
- Use correct vocabulary when speaking and writing about symmetry
- Identify lines of symmetry

### Materials

Each group of students will need from their K'NEX Math and Geometry set:

- 12 blue Rods
- 6 red Rods
- 2 yellow Rods
- 1 gray Rod
- 8 green Connectors
- 3 white Connectors
- 4 red Connectors
- 1 purple and 1 blue Connector
- Building Instructions Booklet: Page 13
- Sheets of 8.5" x 11" paper and pencils

### Each student will need:

- Student Journals

### You will need:

- Vocabulary cards (optional)

### Vocabulary

symmetry, line of symmetry, asymmetrical

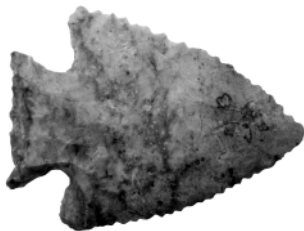

p  
a  
t  
t  
e  
r  
n

### Procedure:

1. Ask each group of students to turn to Page 13 of the Building Instructions booklet and construct the 2-D model that resembles a butterfly.

- Within their groups they should discuss why this is symmetrical.
- Ask them to consider the ways in which their models differ from the real butterfly shown in the photograph on Page 13.
- Have the groups share their ideas in a whole class discussion.
- Ask the students to remove the left side of the model from the central white Connector. Then have them remove the right side. Leave both intact.
- Place the pieces on top of one another. The students should be able to note that the pieces match exactly. This defines a symmetrical figure.

2. With the pieces on top of each other, have the students take the gray Rod and place it on top of the pieces to form a line of symmetry.

- Check the students' work to for accuracy.

More symmetry

symmetry

# More Symmetry



3. Ask the students to remove the yellow Rods from the model and place red Connectors at the open end of each part of the model.

- Have the students trace this figure as follows:
  - a. Place the shape on a blank sheet of paper.
  - b. Place their pencil point into the closed circle of each Connector piece and make a mark.
  - c. Connect the dots using a ruler to form the shape.
- After they have done this, have the students draw as many lines of symmetry as they can.

4. Invite the students to construct the 3-D figure shown on Page 13 of the Building Instructions booklet.

- Have them identify the lines of symmetry.
- Ask the students to try moving the white and/or green connectors while still keeping the model symmetrical.
- Have the students move the white and/or green connectors to make the model **asymmetrical** (not symmetrical).
- Encourage the students to use the other Rods and Connectors and add to the model, while still keeping it symmetrical.
- After the groups have completed their models, have each group share their model, and defend the symmetry of each, with the other groups.

## Assessment:

Ask the students to construct a model of their own design that has symmetry. Have them describe, in writing, what makes their design symmetrical. Check both the model and the student's description. Consider leaving the models on display so that the students can view each other's work.

## Extension:

Encourage the students to modify their K'NEX model so that it more closely resembles the butterfly in the photograph on Page 13 of the Building Instructions booklet. Can they identify the lines of symmetry?

## More Symmetry Terms for the Teacher

**Symmetry:** Correspondence in size, shape, and relative position of parts on opposite sides of a dividing line, or median plane, or about a center, or axis.

**Line of symmetry:** A line that divides a shape into congruent halves.

**Asymmetrical:** Something that is **not** symmetrical.

line

rectangle

t-square

## Lesson 12:

# Patterns and Fractions

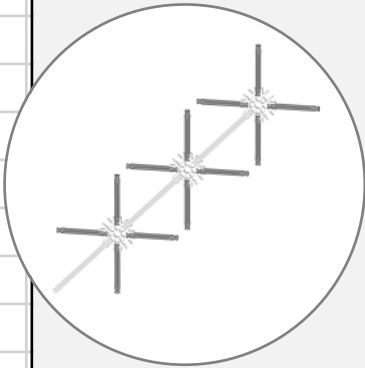

**Time**  
45 minutes – 1 hour

### Objectives

The students will be able to:

- Identify patterns
- Extend patterns
- Use vocabulary associated with patterns and fractions
- Identify fractions to  $\frac{1}{4}$
- Find an equivalent fraction for  $\frac{1}{2}$  and for 1

### Materials

Each group of students will need from their K'NEX Math and Geometry set:

- Blue, yellow and white Rods
- White and red Connectors
- Building Instructions Booklet: Pages 14-15

### Each student will need:

- Student journal

### You will need:

- Overhead projector

### Vocabulary

pattern, fraction, equivalent fraction, midpoint



p  
a  
t  
t  
e  
r  
n

## Procedure:

### Introduction

Ask the students to look carefully at the photograph of the doorway shown on Page 14 of the Building Instructions booklet. Ask them to identify as many different patterns as they can. You might expect them to discover patterns in the floor tiles, the lower wall, the frieze above the wall and the threshold to the interior. They may also point out that the sides of the door are probably symmetrical.

### Part I

1. Ask each group to make the pattern shown on the left hand side of Page 14 of the Building Instructions booklet. (It resembles 3 pinwheels.)

- Ask the students to describe the part of the basic pattern that is repeated.
- Have them use the colors, as well as the numbers of Rods and Connectors, to describe it.
- Ask: What pieces (Rods and Connectors) would you need to repeat the pattern 1 more time, 2 more times, 3 more times?

2. Have the groups of students build the pattern that uses the blue Rods, white Rods, and white Connectors shown on the right hand side of Page 14.

- Ask the students to describe the basic pattern before it is repeated.

# Patterns and Fractions

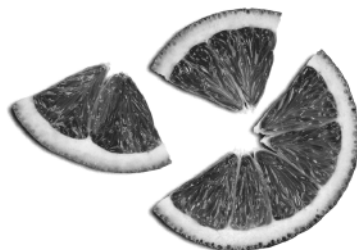
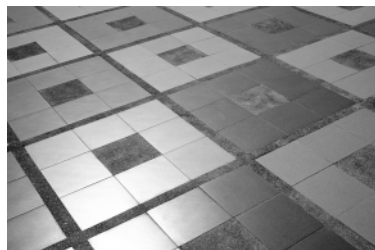

3. Ask: Where do you see patterns in the world around you?
- As an assignment, have the students bring in examples or pictures of examples.

## Part II

4. Using the image at the top right of Page 15 of the Building Instructions booklet as a guide, have the students build the model of the square.

- Ask: How many equal parts are represented in this square?
- After the students answer 4, tell them that each part is called one-fourth. Therefore, there are four-fourths in one whole.

5. Have the groups of students remove one yellow Rod at a time.

- After they remove the first yellow Rod, ask: How many fourths are left on the model. When the students answer 3, tell them that this is called three-fourths.

- When they remove the second Rod, ask the students how many fourths are left. When they answer 2, tell them that we call this two-fourths.

- Have them remove one more Rod and ask how many fourths are left. When they answer one, ask if they know what this is called. (One-fourth)

6. Put models of the whole square and models of the two-fourths on the overhead.

- Elicit from the students that four-fourths will equal one whole, two halves equal one whole and two-fourths will equal one-half.

## Extension

The students will be able to construct a larger square that can be divided into eight equal parts. Once the square is constructed, you can continue with a line of questioning similar to that used above.

- For each side of the square, you will need two blue Rods joined by a white Connector.
- Connect the sides with four red Connectors at the corners.
- Use a white Connector in the center with yellow Rods to connect into the red corner Connectors, alternating with blue Rods to connect into the white Connectors in the midpoint of the sides.
- This will divide the square into eight equal parts.
- By putting models of this square, as well as parts of this square, on the overhead, you can elicit more equivalent fractions. For example: eight-eighths equals one whole, six-eighths equals three-fourths, four-eighths equals one-half, etc.

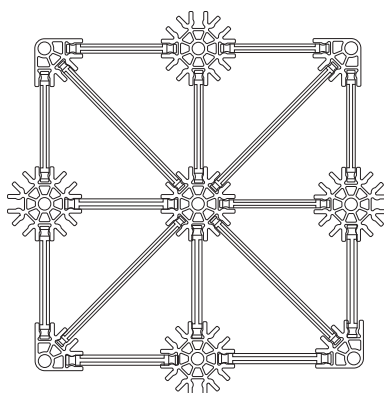

pyramid



triangle

p a t t e r n

angles

90°

symmetry

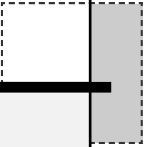

## Pattern and Fraction Terms for the Teacher

**Pattern:** A way that things are arranged so that whatever comes next can be predicted.

**Fraction:** Part of a whole, or part of a set. It can be expressed as a rational number over a rational number. For example:  $\frac{1}{4}$ .

**Equivalent fraction:** Different ways of naming the same fraction. For example:  $\frac{4}{8}$  and  $\frac{2}{4}$  are both equivalent to  $\frac{1}{2}$ .

**Midpoint:** A point that divides a line segment into two congruent line segments.

# Notes

pyramid

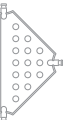

triangle

p a t t e r n

angles

90°



symmetry

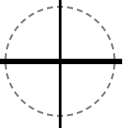

Line segment

Point

Ray

Line

**Point:**

An exact location in space that is usually represented by a dot. It is named with a capital letter.

**Line segment:**

A straight path in space that has two definite endpoints.

**Line:**

A straight path in space that extends infinitely far in both directions. There are no endpoints but it can be named using two points on the line.

**Ray:**

A part of a line with one definite endpoint that extends infinitely in one direction.



Obtuse angle

Angle

Right angle

Acute angle

**Angle:**

A figure that is formed when two rays meet at a common endpoint.

**Obtuse angle:**

An angle whose measure is greater than 90-degrees, or a **right angle**.

**Acute angle:**

An angle whose measure is less than 90-degrees, or a **right angle**.

**Right angle:**

An angle whose measure is exactly 90-degrees.

Congruence

Straight angle

Polygon

Rotational  
symmetry

**Straight angle:**

An angle whose measure is 180-degrees, which forms a straight line.

**Congruence:**

The relationship between two geometric shapes having the same size and shape.

**Rotational symmetry:**

A term describing a shape that remains unchanged when it is turned less than 360-degrees about a fixed point.

**Polygon:**

A simple, closed shape composed of a finite number of line segments, each of which intersects exactly two of the other segments, one at each endpoint.

Right triangle

Triangle

Equilateral  
triangle

Isosceles  
triangle

**Triangle:**

A polygon with three sides.

**Right triangle:**

A triangle with one right angle.

**Isosceles triangle:**

A triangle with two congruent sides.

**Equilateral triangle:**

A triangle with three equal angles.

Square

Hypotenuse

Rectangle

Legs

**Hypotenuse:**

The side in a right triangle that is opposite the right angle.

**Square:**

A closed figure with four equal sides and four equal (right) angles.

**Legs:**

In a right triangle, a side that is not the hypotenuse.

**Rectangle:**

A closed figure with four sides, whose opposite sides are equal and with four equal (right) angles.



**Quadrilateral**

**Similar shapes**

**Trapezoid**

**Parallel lines**

**Similar shapes:**

Two shapes that have the exact same shape – corresponding angles that are congruent and corresponding sides that are proportional.

**Quadrilateral:**

Any four sided, closed figure.

**Parallel lines:**

Lines in the same plane that do not intersect.

**Trapezoid:**

A quadrilateral with exactly one pair of parallel sides.

Pentagon

Parallelogram

Regular  
pentagon

Rhombus

**Parallelogram:**

A quadrilateral with opposite sides that are equal and parallel.

**Pentagon:**

A polygon with five sides

**Rhombus:**

A parallelogram with four congruent sides.

**Regular pentagon:**

A polygon with five congruent sides and five congruent angles.

Octagon

Hexagon

Regular  
octagon

Regular  
hexagon

**Hexagon:**

A polygon with six sides.

**Octagon:**

A polygon with eight sides.

**Regular hexagon:**

A polygon with six congruent sides and six congruent angles.

**Regular octagon:**

A polygon with eight congruent sides and eight congruent angles.

Rectangular  
prism

Polyhedron

Vertex

Cube

**Polyhedron:**

A simple, closed three-dimensional shape formed by plane polygons.

**Rectangular prism:**

A polyhedron that has two congruent parallel faces and a set of parallel edges that connects corresponding vertices of the two faces.

**Cube:**

A regular polyhedron composed of six congruent squares.

**Vertex:**

The point where two rays forming an angle meet; the point where two sides of a polygon meet; or the point where three or more faces of a polygon meet.



**Face**

**Vertices**

**Net**

**Edge**

**Vertices:**

Plural of vertex.

**Face:**

One of the plane surfaces of a polyhedron bounded by edges.

**Edge:**

The line of a three-dimensional shape where two plane faces meet.

**Net:**

A pattern that can be cut out, folded and glued together to make a three-dimensional model of a solid.

Triangular  
pyramid

Base

Square  
pyramid

Pyramid

**Base:**

The side of a shape used as its foundation; the face of a solid used as its foundation.

**Triangular pyramid:**

A pyramid with a triangular base.

**Pyramid:**

A polyhedron that has one base and a set of edges that meet at a single point (apex) that is not the base; all faces, except the base, **MUST** be a triangle; the base **MAY** be a triangle.

**Square pyramid:**

A pyramid with a square base.

Symmetry

Apex

Line (axis)  
of symmetry

Triangular  
prism

**Apex:**

The point off the base of a pyramid where the triangular faces meet.

**Symmetry:**

Correspondence in size, shape, and relative position of parts on opposite sides of a dividing line, or median plane, or about a center, or axis.

**Triangular prism:**

A polyhedron that has two congruent parallel triangular faces and a set of parallel edges that connect corresponding vertices of these two triangular faces.

**Line (axis) of symmetry:**

A line that divides a shape into two congruent parts.

**Fraction**

**Asymmetrical**

**Equivalent  
fraction**

**Pattern**

**Asymmetrical:**

Something that is **not** symmetrical.

**Fraction:**

Part of a whole, or part of a set.  
It can be expressed as a rational number over a rational number.  
For example:  $1/2$ .

**Pattern:**

A way that things are arranged so that whatever comes next can be predicted.

**Equivalent fraction:**

Different ways of naming the same fraction. For example:  $4/8$  and  $2/4$  are both equivalent to  $1/2$ .



**Midpoint**

**Midpoint:**

A point that divides a line segment into two congruent line segments.